



Measuring for Juzo® Compression Sleeves

When to take the measurements

It is important that the edema is at its most reduced state. Most often this is found first thing in the morning or at the end of treatment.

When to measure for a custom garment

Measure for a custom garment after determining that an arm will be too large or too small for a standard size. You will have to take the standard measurements listed to the right and compare to a size chart to determine this.

How to take length measurements

Length measurements should be taken at each circumference. It is recommended that you mark the arm with a non-permanent, non-toxic marker at each circumference measurement made. The length measurement is then taken from point 'c' along the inside of the arm to each circumference point.

Measurement Points

Circumference point 'c' is the area of greatest compression and therefore the most important point. This measurement is found distally on the arm where the wrist meets the hand. One should find the smallest circumference at this point.

Circumference point 'c1' is taken 6cm from point "c"

Circumference point 'd' is the mid-point between the wrist and the elbow.

Circumference point 'e' is found at the middle of the elbow.

Circumference point 'f' is found at the middle of the upper arm, across the biceps.

Circumference point 'g' is taken around the upper arm at the axilla. For ease in determining this point, place a book up into the armpit area. Point 'g' on the arm will be even with the top of the book.

Circumference point 'h' is a vertical measurement taken from the axilla up over the shoulder. For ease in determining this point, keep the book used in point 'g' in place and follow a vertical line up over the shoulder.

Circumference point 'i' is taken from the top of the shoulder (point 'h') across the chest, down around the opposite axilla and returning to point 'h'. Positioning of this strap can vary depending on how the patient prefers to wear the garment.

Length 'g-h' is taken on the outside of the arm from point 'g' up to point 'h'.

Standard Measurements

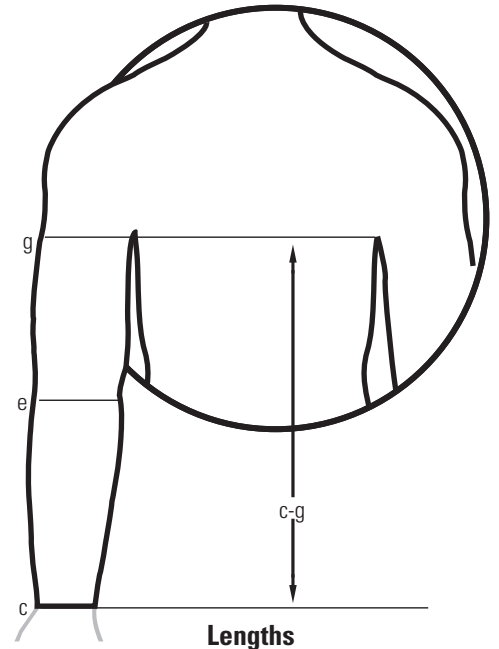

Custom Measurements

